

## IT530CL - IT620CL

1. Retirar la tapa que cubre la transmisión donde se sitúa el embrague.

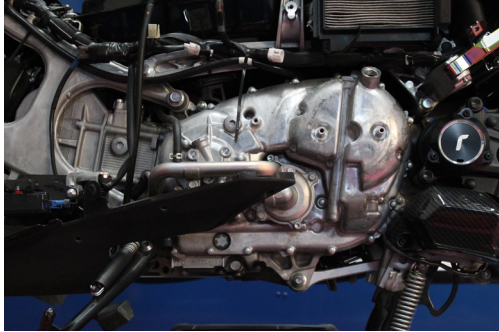

2. Retirar el embrague de origen.

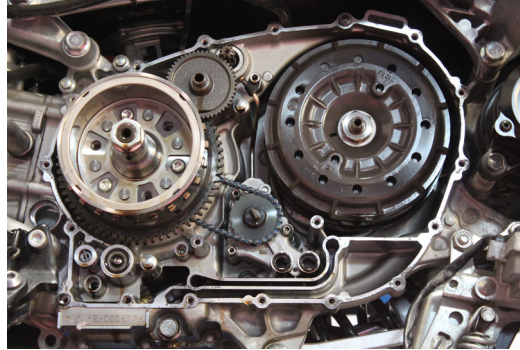

3. Presentar encima de la mesa el embrague de origen junto con el J.Costa.



4. Retirar el conjunto de discos del embrague original y reservar.

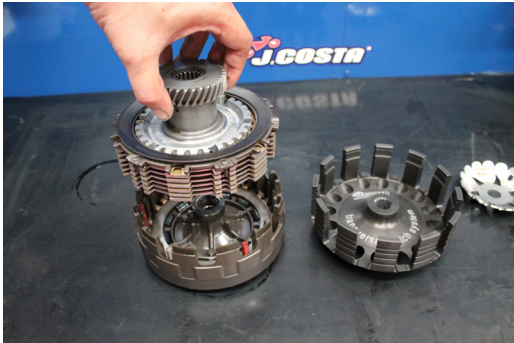

5. Retirar el último disco y colocar en el embrague J.Costa.

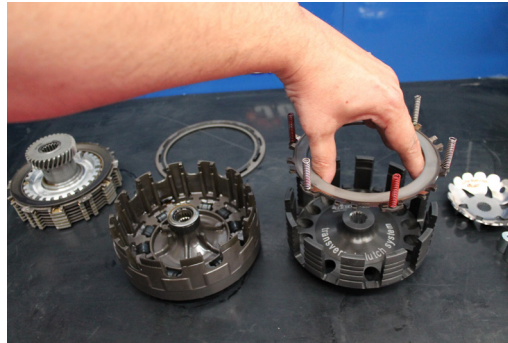

6. Quitar rodamiento central del embrague de origen y colocar en el embrague J.Costa.



7. Introducir el conjunto de discos en el embrague J.Costa y retirar el resorte de embrague.



8. Terminar de montar los discos restantes con el mismo orden que de origen.



9. Una vez terminados los pasos anteriores, debe quedar el embrague J.Costa como en la foto:





## IT530CL-IT620CL

10. Colocar los contrapesos.



11. Montar el conjunto en la scooter.

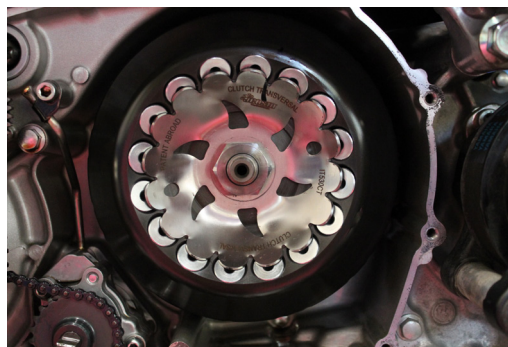

12. Apretar con dinamometrica (9Kg/90Nm).

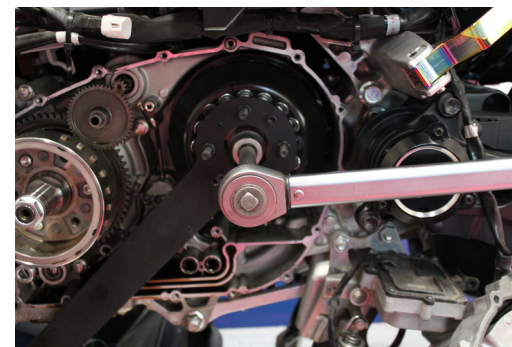

13. Volver a montar la tapa de transmisión que cubre el embrague.



### DESPIECE EMBRAGUE ORIGINAL

AK 550cc

### DESPIECE EMBRAGUE ORIGINAL

T-MAX 530cc

### COMPONENTES

- Arandela: 617WS
- Contrapesos: Ø5 x 16 (IT22165E)
- Cuerpo: 530.E- 550.E
- Araña: IT530EA - IT620EA

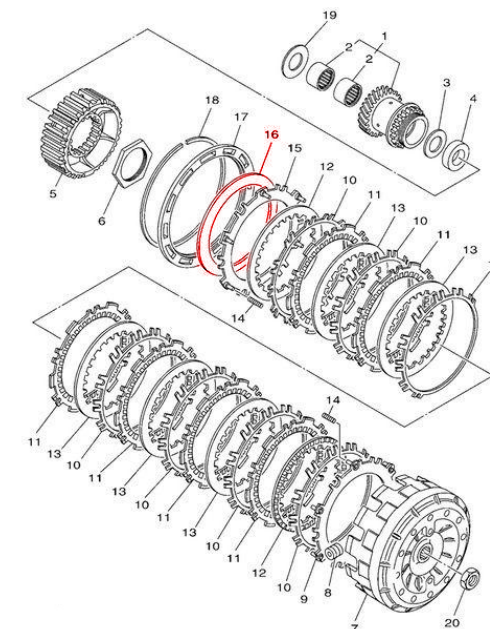
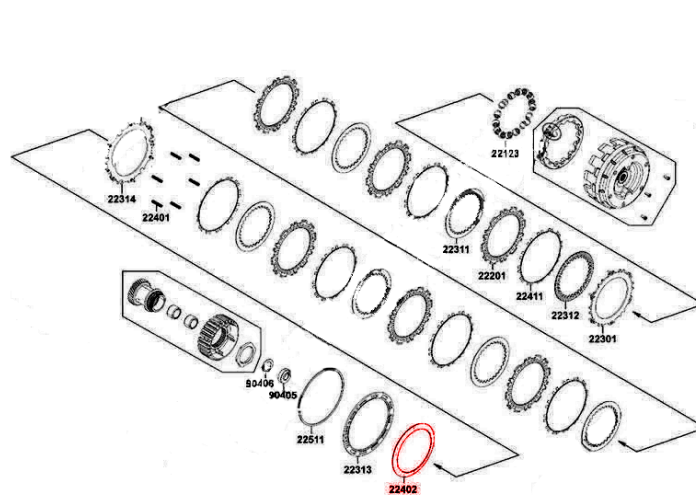

**ATENCIÓN**, retirar el resorte de embrague nº16 (T-MAX 530) o 22402 (AK 550) especificado en en el despiece de embrague original.



# MOUNTING INSTRUCTIONS J.COSTA CLUTCH

## IT530CL - IT620CL

1. Remove the cover that covers the transmission where the clutch is located. 2. Remove the original clutch.

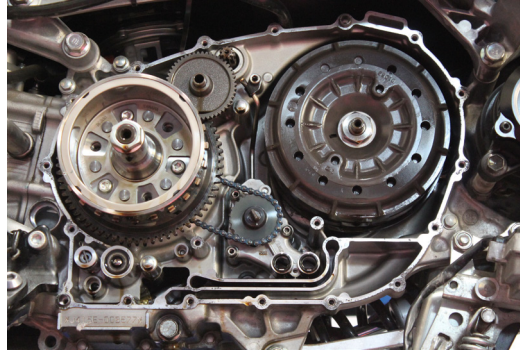

3. In the table presented the original clutch and also J.Costa clutch.



4. Remove the disk clutch from the original one and reserve. 5. Remove the last disk and put in the J.Costa clutch. 6. Remove center bearing from the original clutch and place on the J.Costa clutch.

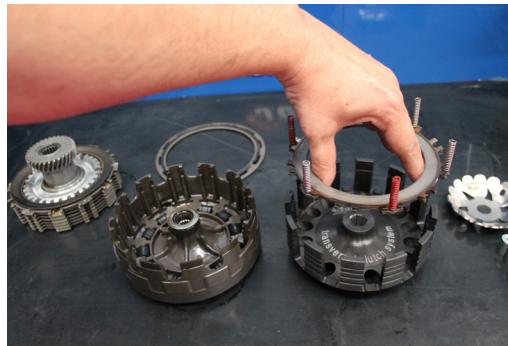

7. Insert the disc assembly into the J.Costa clutch and remove the clutch spring. 8. Finish mounting the remaining disks in the same order as the original. 9. Once the previous steps are finished, the J.Costa clutch should remain as in the photo:





# MOUNTING INSTRUCTIONS J.COSTA CLUTCH

## IT530CL-IT620CL

10. Place the counterweights.



11. Mount the set on the scooter.

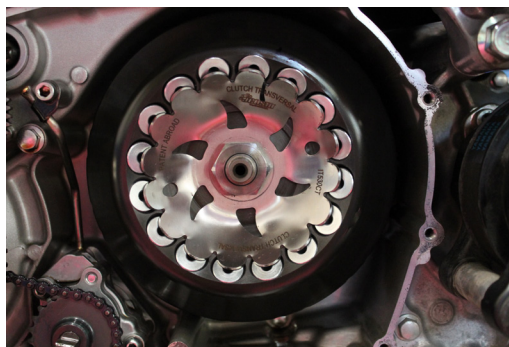

12. Tighten with dynamometer (9Kg / 90Nm).

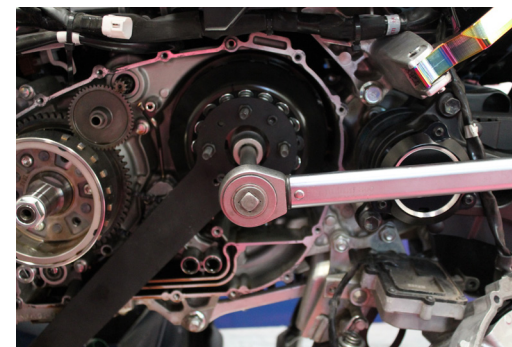

13. Reassemble the transmission cover that covers the clutch.



### ORIGINAL CLUTCH DRAWING FOR

AK 550cc

### ORIGINAL CLUTCH DRAWING FOR

T-MAX 530cc

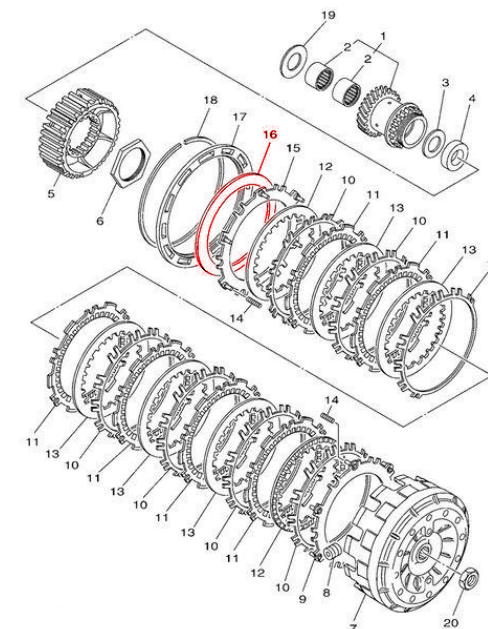
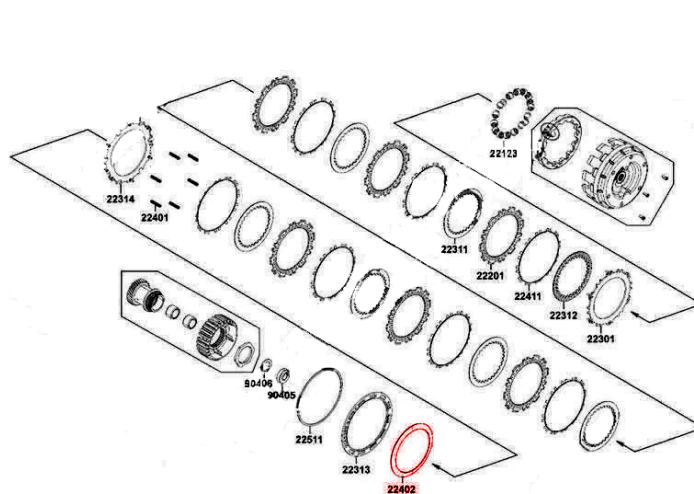

### COMPONENTS

Washer: 617WS

Counterweights:  $\varnothing 5 \times 16$  (IT22165E)

Body: 530.E- 550.E

Spider: IT530EA - IT620EA



**ATTENTION**, for the T-MAX 530 and AK 550 models, remove the clutch spring specified in the original clutch drawing.